

LaserCheck

Bending Angle Measurement System



LaserCheck

Laser-based Bending Angle Measurement System

- Innovative sensors for measuring bending angles on press brakes
- High-tech products "Made in Germany"
- Very high accuracy
- Works contactless
- Integration in existing press brakes possible
- No modifications of tools necessary
- Parallel use of 2 or 4 sensors
- Spring-back calculation with force detection with strain gauges or by detecting end of angle variation
- Connection to Cybelec control via serial interface
- Connection to Delem with Ethernet interface and Modbus
- Integrated OEM solutions for ESA, Amada, Bystronic and others
- Easy to use
- Delivered fully wired and calibrated

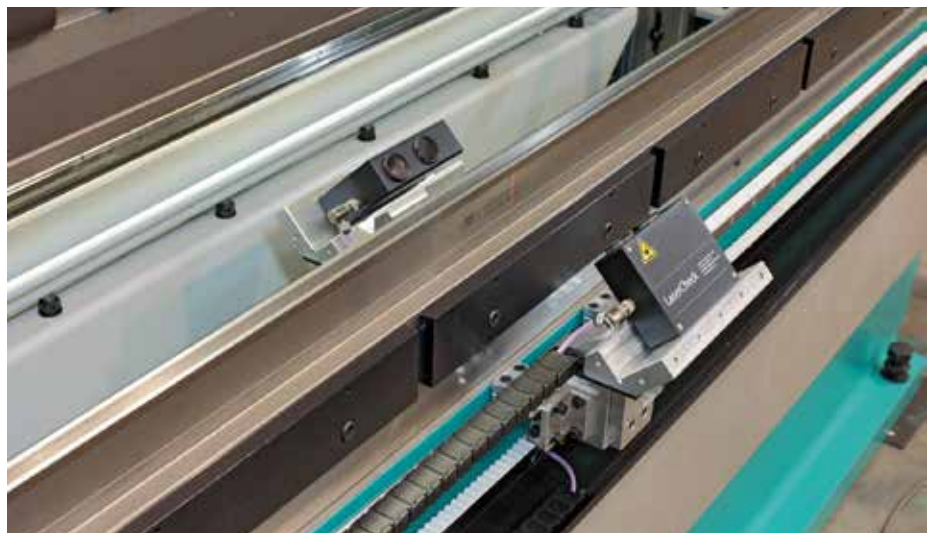

Manufacturing sheet metal parts with accurate bending angles that are kept constant all times often meets a problem during the actual production process: different parameters in material thickness and stresses.

In order to solve this problem and to make use also of minor quality materials safe for the user, data M Engineering has developed a powerful solution for measuring bending angles in press brakes - the LaserCheck.

LaserCheck enables the user to determine the exact bending angle for press brakes with laser triangulation together with strain gauges - and it works contactless.

Working principle

The bending angle is measured by scanning the projection of the laser beam to the surface of the sheet metal with the CMOS camera. The angle between the laser and the viewing axis of the camera enables a distance measurement. The angle between sensor and sheet metal is calculated from these distances. With a second sensor at the opposite site the bending angle is calculated.

Characteristics

The LaserCheck sensor is mounted on the press brake, below the die, with an angle of 35° - 55° to the vertical. The working distance (between sensor and sheet) is 80-300mm, depending on the sensor type. It is moveable along the die either manually or automatically. Due to its mounting position the measuring range is 30° to 180° bending angle. For each measuring position there are 2 sensors needed. Four sensors enable an independent correction of the beam to compensate angle differences in long bends.

Designed for industrial applications

The sensors in the LaserCheck product range are especially designed for sheet metal applications. Due to their robust construction and user friendly technical features, they achieve precise measurement results even in harsh ambient conditions.

By carefully miniaturising every component, we have created small and robust sensors, that fit on any press brake.

Spring-back measurement

Spring-back is measured by releasing the sheet metal in two different ways:

- Opening until end of angle variation. The spring-back angle is measured directly. This strategy is necessary for bends with small forces.
- Opening until the bending force is falling below a predefined limit. Strain gauges are measuring the bending forces simultaneously at both side frames. The spring-back angle is calculated from angles and forces and the sheet metal will be overbent accordingly. Force measurement with residual forces is improving the accuracy when using tools with larger radii or asymmetric parts when a complete release is not possible without losing the correct bending position.

Calibration & Accuracy

The sensor accuracy is better than $\pm 0.1^\circ$. The bending accuracy is influenced by the control, the machine accuracy, the tools and the material. To increase the bending accuracy the sensors will be calibrated after mounting, so the mounting errors are reduced.

Calibration with LC-Adjust

After mounting, the sensors shall be calibrated in the machine with our calibration unit LC-Adjust. This allows highest accuracy with errors less than $\pm 0.1^\circ$ in the full measuring range.

Precalibration

All sensors are pre-calibrated in order to work with reasonable results also without calibration. Only the mounting angle must be defined. Linearity errors can be input for different measuring situations from the machine user.

To document the performance capability of the LaserCheck sensors, each sensor is supplied with its own calibration certificate.

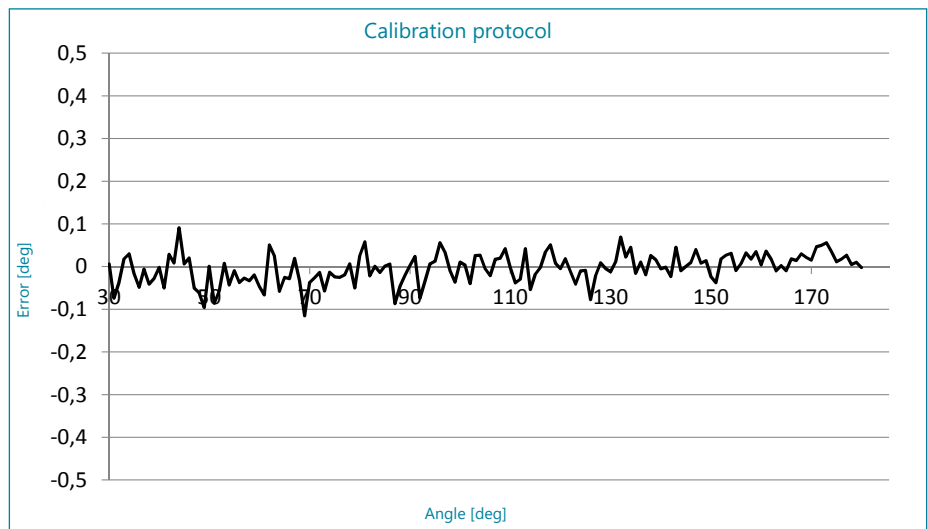

Real time measurement

The fast GigE cameras inside the LaserCheck sensors allow real time measurement with refresh rates up to 100Hz. USB sensors are supporting refresh rates up to 50Hz.

Requirements:

- Delem LUAP with DM-101RS module
- Cybelec ModEva with option 66
- Other controllers with real time support

Advantage:

- Bending process is not interrupted
- Fast bending process
- Spring-back measurement without force measurement possible

Controls (Integration)

Available Interfaces:

- Serial Interface for Cybelec ModEva.
The LaserCheck sends the angles via RS232 and the forces with an analogue signal to a NLR-card
- Serial Interface for Amada controls
- Combined TCP/IP-Modbus interface for Delem DA66T and DA 69T. The angles are sent to a DM-101RS module via Modbus. Force sensors are connected to an analogue input of the module. For the control of the bending process a LUAP is also provided.
- Open TCP/IP interface for Bystronic, ESA, Robosoft and Gasparini controls
- CANopen
- EtherCAT



Why LaserCheck?

- LaserCheck does not only include angle sensors. It is a complete system to be connected to press brakes. It includes different interfaces for press brake controllers, strain gauge sensors to detect spring-back and motorized systems for sensor movements.
- Well established technology. The separation of sensors and CPUs allows cost efficient solutions if the controls are able to run the LaserCheck software (Cybelec, Bystronic and ESA controls).
- Long time support for all components
- Bending angle correction during the bend process - Perfect results from the first bend
- World wide setup support
- Training and support worldwide or in-house

Why data M Engineering?

data M Engineering offers also services to achieve best results for your projects:

Training in our premises in Holzkirchen, where you learn:

- How to mount LaserCheck
- Parameterisation
- Interfacing to LaserCheck (TCP/IP, Modbus and others)
- LUA programming for Delem controls

Software Development

- Software development for different measuring jobs
- Software modifications for special interfaces

Engineering Services

- Customised solutions for special purpose like bending hexagonal tubes
- Customised sensors with long working distances up to 1000 mm
- Additional axes for sensor movements including controls
- Sensor dependent crowning control



<u>Specification LaserCheck</u>		LaserCheck 10	LaserCheck 11	LaserCheck 12	with option Range Extender
Die width [mm]	from to	V6 V100	V6 V100	V6 V100	V6 V140
Die height [mm]	from to	55 85	55 85	55 85	55 120
Stand-off distance [mm] (Optimum distance between the sensor and the sheet metal)		80-160	80-160	160-300	
Mounting angle		45° ±10°	45° ±10°	45° ±10°	
Cable lengths		5m + Repeater (Max. 20m)	Max. 50m	Max. 50m	
Option Longitudinal Adjustment		with servo or stepper motors (completely wired and parametrised with inductive limit switches)			
<u>General Technical Details</u>		LaserCheck 10	LaserCheck 11	LaserCheck 12	with option Range Extender
Measurement range		30°-180°			
Typical scan rate*		20-50 Hz	50-100 Hz	50-100 Hz	
Precision of sensor		better than ±0,1°			
Camera Interface		USB 2.0	Gbit Ethernet (1 Gbit/sec)	Gbit Ethernet (1 Gbit/sec)	
Optical class		1/2"-CMOS			
Resolution (h x v)		1280x1024 (1,3 MP)			
Inputs			Trigger signal	Trigger signal	
Input voltage Power		5 VDC 500mA via USB	24 VDC 90mA	24 VDC 90mA	24 VDC 2A + Sensor
Laser wavelength		670 nm (red visible)			
Laser class		2M			
Life time: Laser diode	at 0° at 40° C	50.000 h 10.000 h			
EMC test		EMC-conform according EN 61000			
Protection class		III, as per EN 61140			
Enclosure rating		IP64	IP64	IP64	IP54
Air humidity		Maximum 90% RH, non-condensing			
Temperature	operation storage	0 - 40° C -20 - 70° C			
Interface		TCP/IP, Modbus, RS232, EtherCAT			
Image processing		Control computer with Win10 IoT Enterprise LTSB 64 Bit (Direct sensor connection to the control possible)			

* Scan rate is dependent on the configured field of view, measurement range & exposure time.

LaserCheck 10

USB | For machines up to 100 mm die width

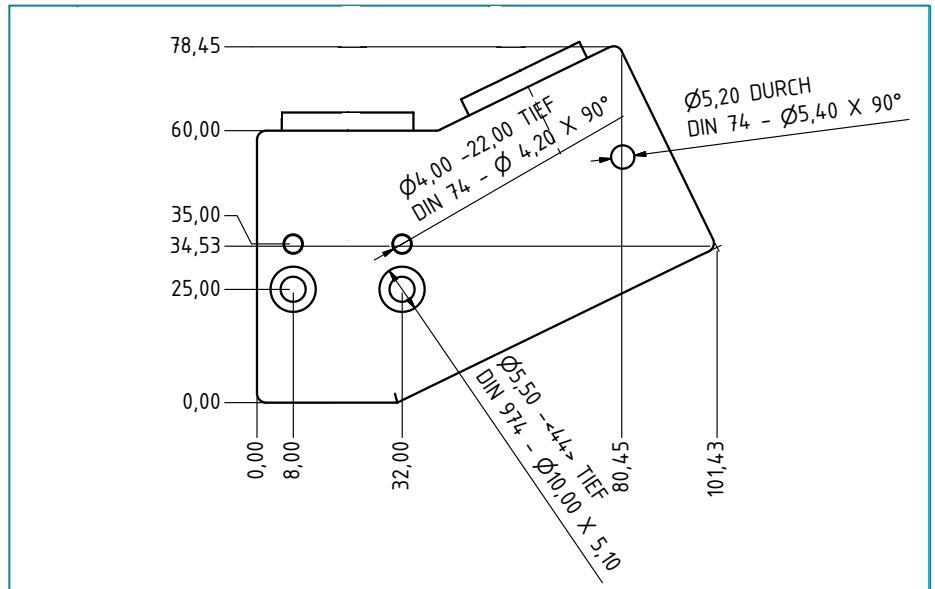

LaserCheck 11

Gigabit-Ethernet | For machines up to 100 mm die width

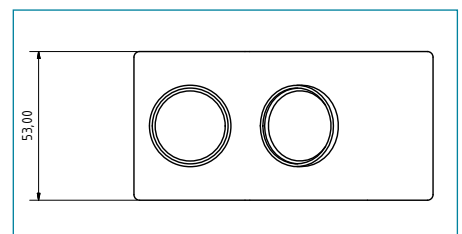
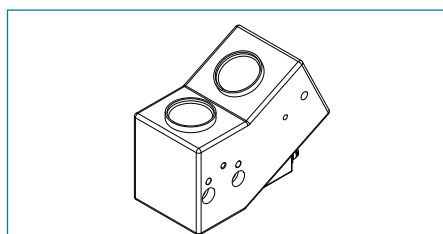
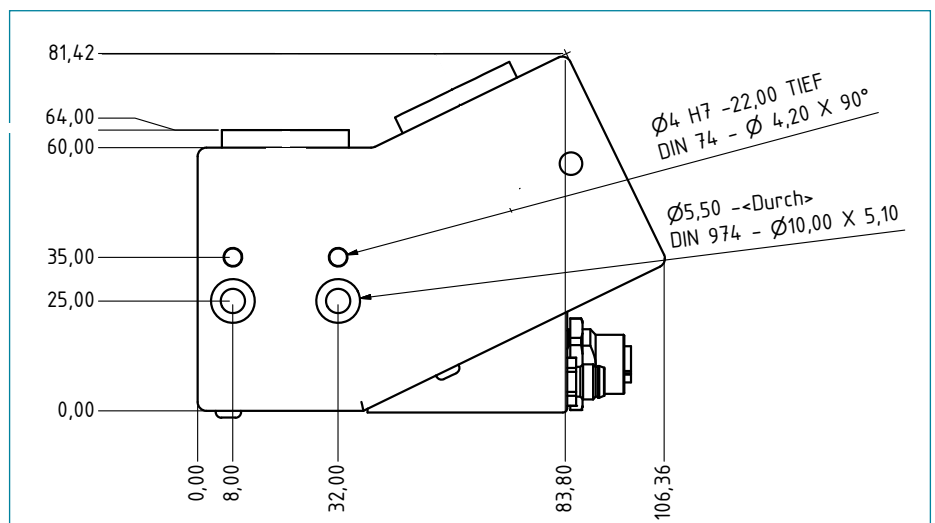

LaserCheck 12

Gigabit - Ethernet | For large machines up to 300 mm working distance

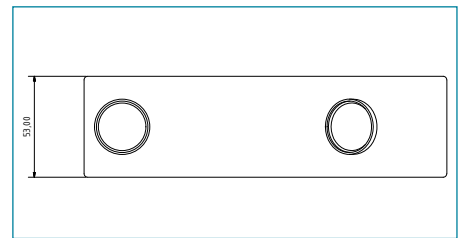
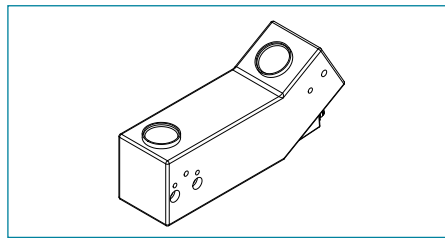
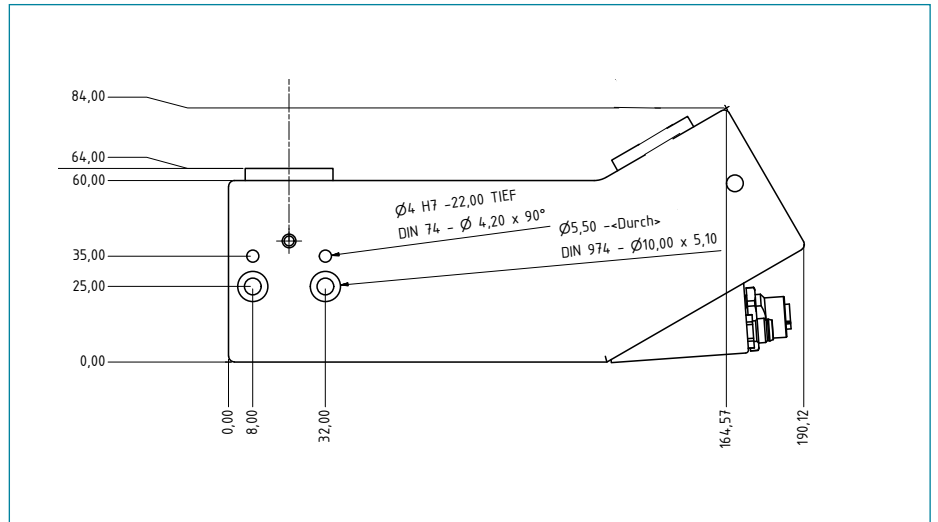

Range Extender

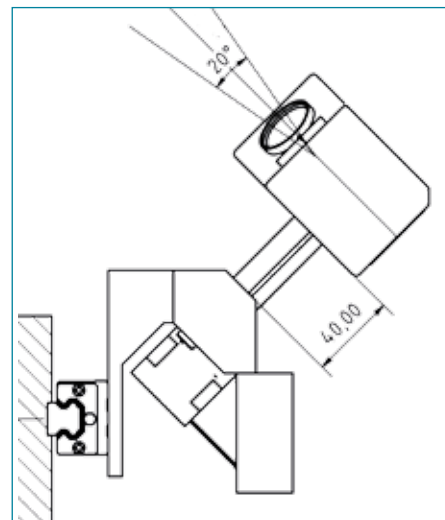

For LaserCheck 10,11,12 | Extends the measuring range for larger tools



Cables | Accessoires | Options

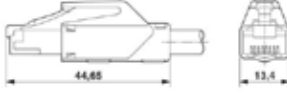

Cables

Ethernet connecting cable (for LaserCheck 11 + 12)

GigE connecting cable	Ethernet cable, CAT6A, M12 plug on RJ45 plug Variable cable length (up to 50m)	
Cable:	Ethernet 10 Gbit PUR cable, shielded, flame retardant, oil-resistant, bio-oil-resistant, hydrolysis resistant and microbe resistant, outer diameter: $D = 6,4\text{mm} \pm 0,2\text{mm}$ Minimum bending radius: Fixed installation: 26mm Flexible installation: 52mm	
Connector:	Head 1: M12 straight male plug, 10G, X-coded, 8-pin, shielded, IP67 Head 2: RJ45 IP20	
		

Article-number: 10006108 (with 10m cable) | Article-number: 10005154 (with 15m cable)

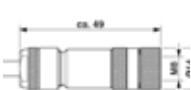

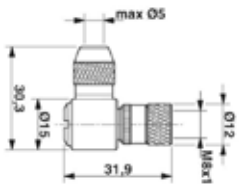
USB connecting cable (for LaserCheck 10)



USB 2.0 special-cable	max. 5m (+ optional USB-Extension)	
Cable:	TPE cable, shielded, flame retardant, oil-resistant, bio-oil-resistant, hydrolysis resistant and microbe resistant, adapted to the requirements in drag chains, outer diameter: $5\text{mm} \pm 0,2\text{mm}$ Minimum bending radius: Fixed installation: 37.5mm Flexible installation: 50mm	
Connector:	Head 1: M8 female plug, 4-pin, shielded, IP67 Head 2: USB A connector	
Straight plug:	Angle plug:	
		
		

Article-number: 10005026

Article-number: 10005512

Motor cable (for LaserCheck with Range Extender)

Power supply and trigger cable	connected to sensor & USB/RS485 Bus coupler Variable cable length (up to 40m)	
Cable	PUR halogen-free cable, flame retardant, oil-resistant, bio-oil-resistant, hydrolysis resistant and microbe resistant, adapted to the requirements in drag chains. Outer diameter: $5,9\text{mm} \pm 0,2\text{mm}$ Minimum bending radius: Fixed installation: 47.2mm Flexible installation: 59mm	
Connector	Head 1: M8 female plug, straight or angle, 4-pin., IP67 Head 2: not connected	
		
Article-number: 10006199 (with 10m cable)		

Power cable (for LaserCheck 11)	
Power supply and trigger cable	M8 connector / free cable end 12-24V Variable cable length (up to 40m)
Cable:	PUR halogen-free cable, flame retardant, oil-resistant, bio-oil-resistant, hydrolysis resistant and microbe resistant, adapted to the requirements in drag chains. Flexible cable conduit capable Outer diameter: 4,4mm ±0,2mm Minimum bending radius: Fixed installation: 26mm Flexible installation: 52mm
Connector:	Head 1: M8 female plug, straight or angle, 4-pin., IP67 Head 2: not connected
	
Article-number: 10005851 (with 10m cable) Article-number: 10006036 (with 15m cable)	

Accessoires

Gigabit Ethernet Switch

Industrial 5-port slim type switch DIN-Rail and wall mounting enabled
24V power supply
Article-number: 10005853



USB 2.0 Extension cable

5m extension
Article-number: 10003666



Similar to illustration

USB 2.0 Hub with 4 Ports

Easy installation with included DIN-Rail Kit
Power +7 up to 24V DC – The standard in industrial environment
Article-number: 10005631



Force measurement

Special sensors for spring-back measurement without fully releasing the sheet metal, due to asymmetry / weight / stiffness of parts or tools etc

Measurement Amplifier

Special amplifier for strain gauges with autoscaling function



Strain gauges

High-resolution extensometer for indirect measurement of bending forces during the deformation of the machine frame.
Unlike strain sensors DA40, time-consuming drilling of threads is not required because of integrated high-performance magnets.

Dimensions: 38 mm x 68 mm x 20 mm;
Mounting: 4 integrated magnetic clamps;
Connection: M12 Plug 4 pins (male);
IP protection class: IP 65;
Housing: aluminium alloy

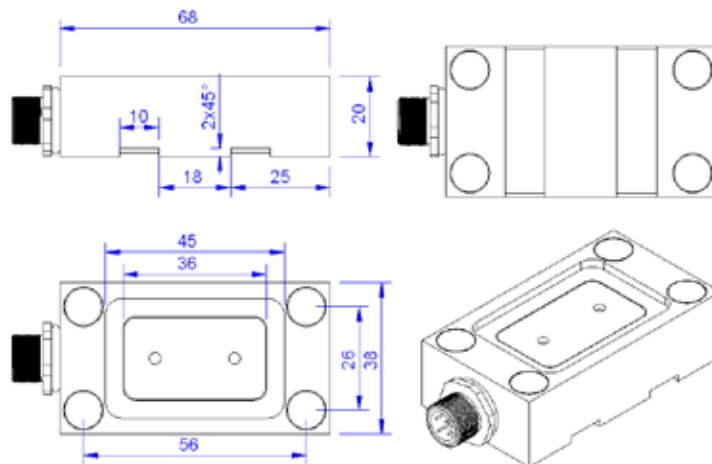

Force measurement Kit:

- One Amplifier with two strain gauges
- Fully wired
- All parts pluggable

Options



Sensors
for measuring from the punch with long working distance of 900mm



Motorized height adjustment
for different tool heights.

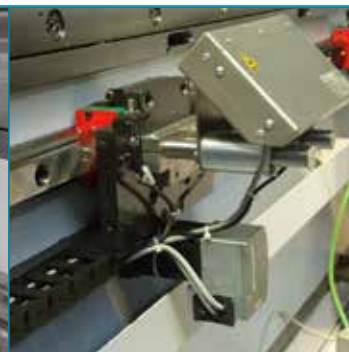

Longitudinal Adjustment
Necessary for different bending stations



Range Extender
for LaserCheck 10 & 11
Necessary for large tool heights.

Image processing

Industrial computer

Computer	ECW	DRPC	UIBX
System	Fanless Embedded System	Fanless DIN-Rail Embedded System, with programmable OLED display	Fanless Embedded System
Housing	Mini chassis for wall mounting	Mini chassis for DIN-rail mounting	Ultra mini chassis for wall mounting or DIN-rail mounting
Dimension	229 x 64 x 132 mm (W x H x D)	74,08 x 140 x 171,5 mm (W x D x H)	136,6 x 102,4 x 52 mm (W x D x H)
Processor	Intel® Celeron® J1900 processor 2 GHz (up to 2.42 GHz, Quad-Core CPU)	Intel® Atom™ E3845 processor 1.91 GHz (Quad-Core CPU)	Intel® Celeron® N3160 processor 1.60 GHz (up to 2.24 GHz, Quad-Core CPU)
System memory	4 GB DDR3L SO-DIMM memory	4 GB DDR3L SO-DIMM memory	4 GB DDR3L SO-DIMM memory
Storage medium	Industrial 2,5" SSD with 64GB	Industrial 2,5" SSD with 64GB	Industrial 2,5" SSD with 64GB
USB-Ports 2.0	3	2	-
USB-Ports 3.0	1	2	4
Ethernet	2x GbE	2x GbE	2x GbE
COM Ports	3x RS-232 1x RS-422/485	2x RS-232 2x RS-422/485	2x RS-232/422/485 (RJ-45)
Display & Resolution	1x VGA Up to 2560x1600@60Hz	1x VGA 1x HDMI Up to 1920 x 1200@60Hz	1x VGA 1x HDMI HDMI: 3840 x 2160@30MHz, VGA: 1920 x1200@60Hz
Input power range	3-pin terminal block: 9-36VDC	3-pin terminal block: 9-28VDC	DC Jack: 12VDC (power adapter)
Operating temperature	-20°C ~ 60°C with air flow (SSD), 10% ~ 95%, non-condensing	-20°C ~ 60°C with air flow (SSD), 5% ~ 95%, non-condensing	-20°C ~60°C with air flow (SSD), 10% ~ 95%, non-condensing
Operating Vibration	MIL-STD-810F 514.5C-2 (SSD)	MIL-STD-810F 514.5C-2 (SSD)	MIL-STD-810F 514.5 C-2 (SSD)
Operating system	Windows® 10 IoT Enterprise LTSB (64Bit)	Windows® 10 IoT Enterprise LTSB (64Bit)	Windows® 10 IoT Enterprise LTSB (64Bit)

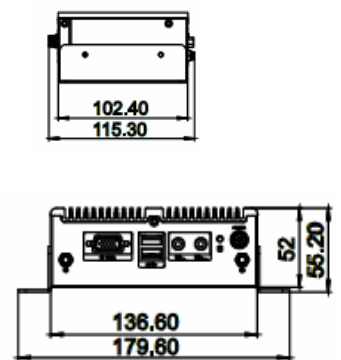
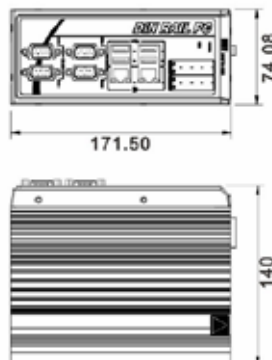
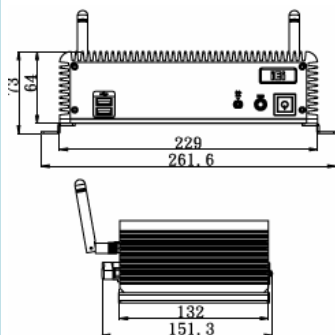



Hightech made in Germany

With innovative and fresh technical solutions we have been able to make a name for ourselves worldwide.

We develop and manufacture sophisticated mechatronic solutions for the sheet metal industries (LaserCheck) and ceramic industries (DecalApplicator und DecalCutter). Furthermore different other industrial sectors are served with special machines (HexapodRobot, medical instruments).

Wherever you are, we are available with our know-how, early stage consultancy, with solutions and products, the pre and post installation support, spares management and training.

data M Engineering GmbH

Konrad-Zuse-Straße 3
83607 Holzkirchen

Germany

TEL: +49 8024 47028-0
FAX: +49 8024 47028-25
E-MAIL: info@datam-eng.de

INTERNET: www.datam-eng.de



www.datam-eng.de